

Name: _____

Date: _____

Running on Renewables

Extension Worksheet Tracks 1 and 2

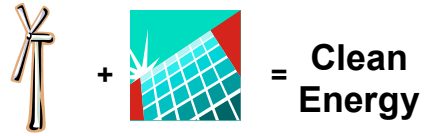

The components you had HOMER analyze included a diesel generator. What if the school wanted to run on only a PV array and wind turbines?

1. Remove the diesel generator from the list of equipment to consider by clicking on the Add/Remove button and deselecting the generator.

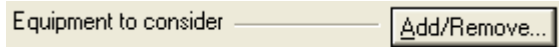

2. Click on the Calculate button. What does this do to the simulation?

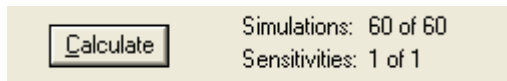

3. Your system can no longer supply the electrical needs for the school because the generator was removed. You must now store the energy that you create from your PV array and your wind turbines so that you can meet the energy needs. Let's first try and add a battery to your list of equipment.

4. Click on the Add/Remove button and check the battery box, click OK.



5. Next click on the battery icon as shown below.

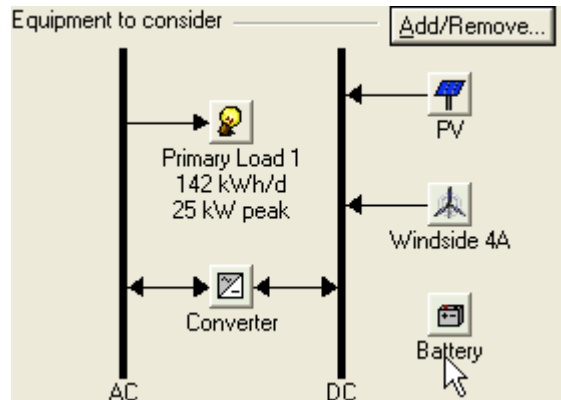

6. Select the Trojan L16P battery from the drop down list, the battery cost is \$240.00 per 6 volts for both the initial capital investment and the replacement cost. You will need at least 5 batteries to run our 10kw PV. (Note: The higher the voltage the more efficient the system is.)
7. See if you can add enough batteries to meet your school's electrical demand. You may need to add many batteries at one time, for example you may want multiples of 10 or 20 instead of 1 or 5. Click OK.

8. Click Calculate. What happens? Did your system work or are you still receiving an error?

9. You may need to add more converter capacity because batteries produce DC. Let's try ramping up your converter; click on your converter icon and change the size of your converter to at least 40kw/h. Also increase the sizes to consider in the right column. (Hint: Think big!)

10. Click Calculate. What happens? Did your system work or are you still receiving an error?

11. If you received an error again you must adjust your system by changing the parameters of the Wind Turbine and PV array. Exaggerate your parameters this time until you find an all-renewable system that works.

12. Click Calculate. What happens? Did your system work or are you still receiving an error? Keep adjusting as needed until your systems works.

13. How is the electricity being generated now?

14. What has this done to the cost of the system?

15. How many Wind Turbines did it take to make your system work? _____

16. How many batteries did your final system need? _____

17. What size of PV array did you use? _____ kW

