

Name(s): _____

Maximum Power Point (Student Handout)
(The Principles of Optimizing Photovoltaic Cell Power Output)

Part 1: Investigating How a Photovoltaic (PV) System Works

Take a look at the animation of a PV system with your partner(s) at:

<http://www.greenspec.co.uk/html/design/materials/pvcells.html>

Work all the way through and answer the questions below together when you are finished.

Part 1

1. Name the major parts of the photovoltaic system? (Also include the job of each part you list).

2. What does the energy output of a solar (PV) cell depend upon?

3. Experiment with the “Energy Output” segment of the animation? Which direction and tilt combinations produce the highest output for the PV cell?

4. Why is it important to find out the highest power output for a PV cell?

Part 2 (Experimenting with a Photovoltaic Cell: How Can We Obtain Maximum Power?)

In this part of the activity you will be measuring the voltage and current produced by a photovoltaic cell under various conditions. While conducting these experiments, think about which conditions help the cell produce the most power! (Power=Current x Voltage)

STEP 1: Set up your model PV system:

- 1) Lay the solar panel on a clean surface, silicon side down. Wire the panel to the multimeter as shown in Figure 1 below.

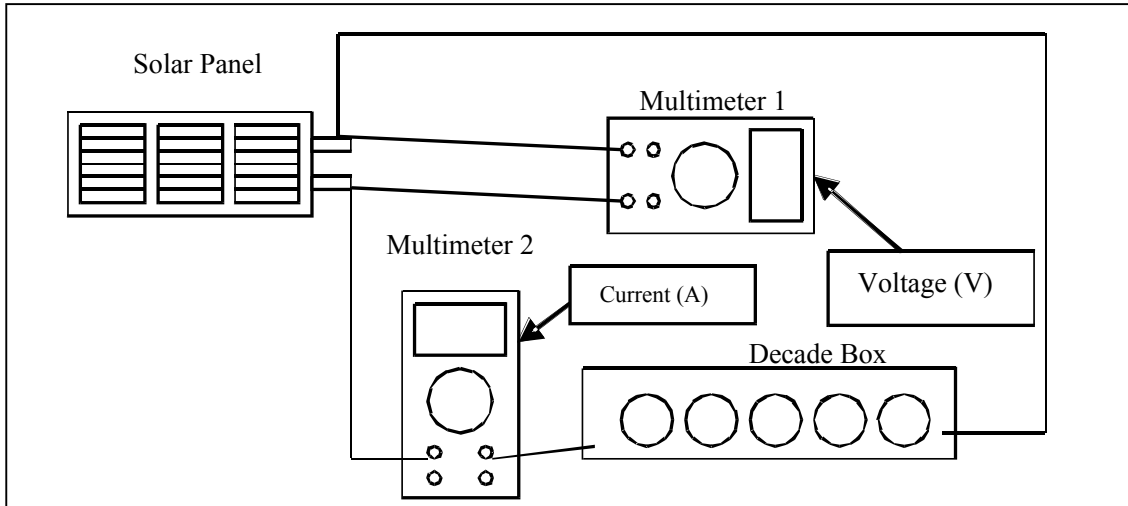

Figure 1. Diagram of a PV panel wired in series with a multimeter.

- a) Clip one end of a wire with alligator clips to one of the metal tabs on the back of the solar panel. Connect the other end of the wire to the red lead of the multimeter and to one arm of a 100 ohm (Ω) resistor at the same time. Take a second wire with alligator clips and clip one end to the second arm of the same resistor and to the black lead of the multimeter. Attach the other clip to the second metal arm on the solar panel.



Great job! Take a look at the following question and get ready to collect some data!

What purpose do you think the resistor serves?

- b) Turn the solar panel over and turn on the multimeter. (To get a proper reading you should be using the 200mA DC setting for current and the 20V DC setting for voltage). Measure the current (I). What is it?

- c) Measure the voltage (V). What is it? _____

STEP 2: Find out how the “tilt” (angle) and direction of a PV panel affect its power output:

1. Obtain a gnomon stand from your teacher, attach your solar panel, and face it towards the sun. Use a compass to find the direction in which you are facing and record that in Table 1.

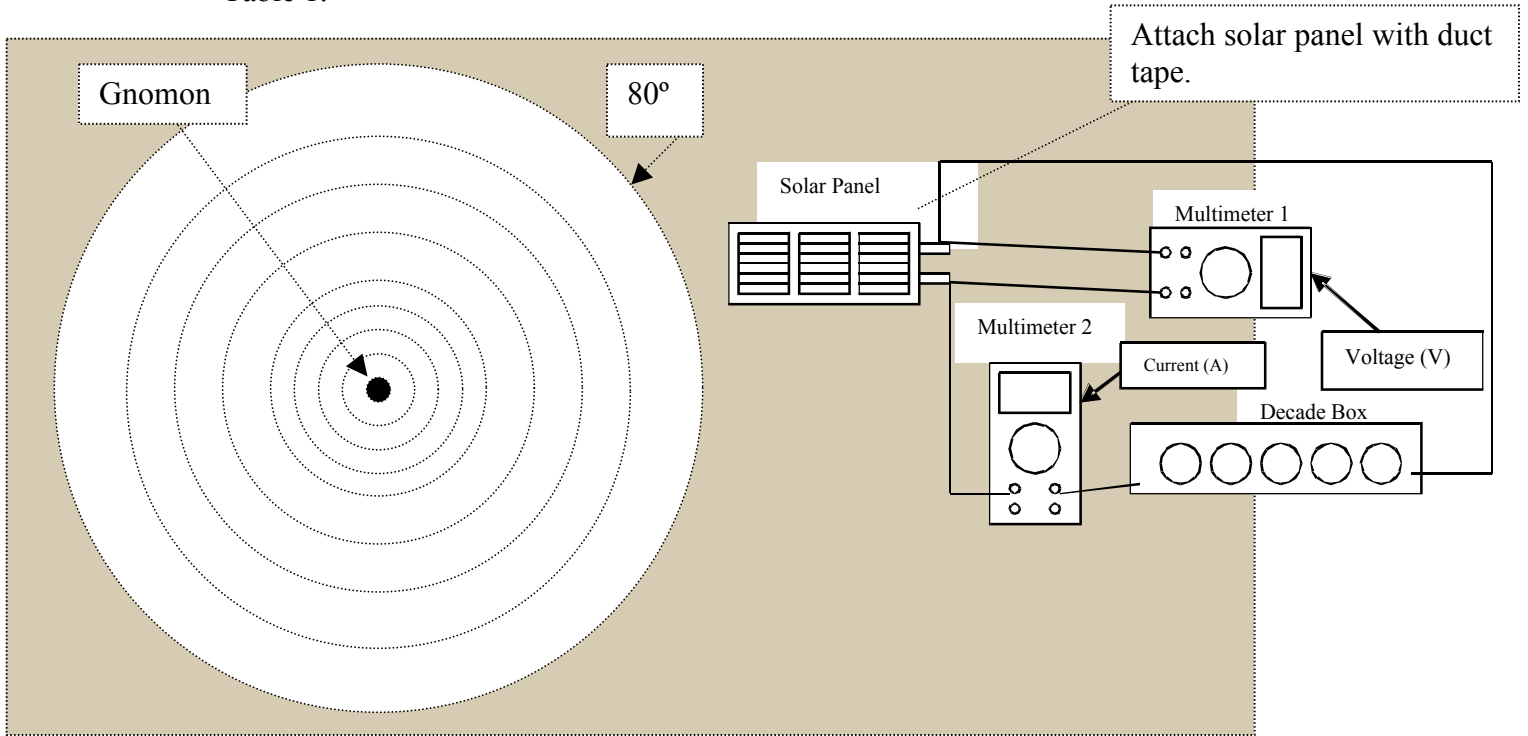

Figure 2. Gnomon Stand with Solar Panel Attached.

- a) Tilt the gnomon stand so that the tip of the gnomon’s shadow falls upon the circle for each angle and measure the current and voltage. Record your data in Table 1 below and calculate the power output of the cell for each angle. (Don’t forget to record the resistance used in your system and time of day in Table 1 below.)

Table 1.

| Direction (N, S, E, W) | Time: | Resistance: | |
|---------------------------------|----------------|-------------|---------------|
| Angle of Incidence (in degrees) | Current (amps) | Voltage (V) | Power (watts) |
| 10 | | | |
| 20 | | | |
| 30 | | | |
| 40 | | | |
| 50 | | | |
| 60 | | | |
| 70 | | | |
| 80 | | | |

b) At what angle and direction does the cell produce the most power? Why do you think this is so?

c) Do you think that conducting this experiment at a different time during the day would affect your results? If so, why?

d) How do you think that conducting this experiment during the different seasons would affect your results?

STEP 3: Questions to Consider

e) Based upon your observations and evidence, what are the **best conditions** for gaining the most power from a PV cell?

f) What are some of the **limits** of using PV panels to make electricity?



g) What are some **obstacles** to using PV panels to do work like powering automobiles?

Part 3 (Graphing and Analyzing Your Class's PV Panel Data)⁷

In this section, you will use the data that your class has gathered in the previous pages to create two graphs. The graphs will be your tools to find the “Maximum Power Point” (MPP) for your PV panel!

- 1) Remember Ohm’s law as you are working through this section:

| |
|--|
| Ohm’s law: Voltage (V) = Resistance (Ω) x Current (A) |
|--|

| | |
|--|---|
|  Remember that electric power is measured in watts (W) where: |  |
| Power (W) = Voltage (V) x Current (A) | |

- 2) Calculate and record the output power for each resistance value in Table 2 below.

Table 2. Class Data for Current & Voltage with Different Resistances in Series

| Resistance (Ω) | Angle of Incidence (degrees) | Voltage (V) “volts” | Current (A) “amperes” | Power (W) “watts” |
|-------------------------|------------------------------|---------------------|-----------------------|-------------------|
| | | | | |
| | | | | |
| | | | | |
| | | | | |
| | | | | |
| | | | | |
| | | | | |

- 3) Create the I-V Curve for your solar panel.

On a separate sheet of paper or using Microsoft Excel, plot the class data from Table 2 for current versus voltage to obtain the panel’s **I-V curve**. Plot current (A) on the y-axis and voltage (V) on the x-axis. Label and show the scale of each axis.

⁷ Adapted from Solar Kit Lesson #11, “Power Maximum: An Electrical Determination” of School Power Naturally’s Solar Education for NY.

- 4) Next, create the Power Curve for your solar panel.

On a separate sheet of paper or using Microsoft Excel, plot power (that you calculated and entered into Table 2) versus voltage to obtain the panel's **power curve**. Plot power (W) on the y -axis and voltage (V) on the x -axis. Label and show the scale of each axis.

- 5) From the power-voltage graph, what is the value of maximum power and what is the voltage at maximum power?



- 6) From both graphs, what is the current at maximum power? (From the maximum power point on the power curve, trace upward parallel to the y -axis until you intersect the I-V curve. Trace left parallel to the x -axis until you reach the y -axis.)



- 7) Attach copies of your graphs to this handout for full credit.